

# Unit pump

Unit pump for large engines



**BOSCH**  
Invented for life

Electronically controlled – quick, continuous adjustment of the injection quantity is therefore possible

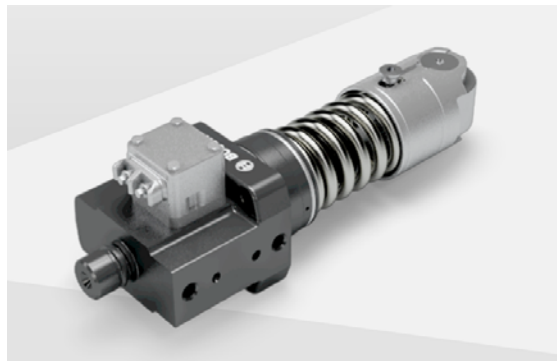

up to

**1,800 bar**

**of injection pressure for efficient combustion**

up to

**20,000 h**

**of reliable operation due to robust design**

- ▶ With high pressure, the unit pump ensures excellent mixture preparation and combustion of fuel with specific high performance.
- ▶ This contributes towards compliance with emission guidelines and a reduction in fuel consumption.
- ▶ A fuel pump (injection pump) is fitted for each engine cylinder. The pump piston is fitted in the pump cylinder with such precision that high injection pressure is guaranteed, even at low speeds. The 2/2-way valve provides the full range of functions.